

Air heater KW2.0 5.0 Manual



Tips:

- 1).  On / off. Press 1 -2 seconds.
- 2). The fuel pipe should be 1.5 meter - 2 meters.
- 3). The voltage would be better, if 11.5 V - 12.8 volts.

Introduction

Application field of Air heater

The air heater is not affected by the engine ,and it is supplied for the following vehicles with corresponding power.

- All kinds of auto and trailers.
- Construction machinery
- Agricultural machinery
- Boat, ship, yacht
- Caravan

Function

- Warm-up, defrost glass
- Heat and keep warm for the followed area:
 - Driving cab, cabin
 - Cargo hold
 - Interior of staff carrier
 - Caravan

The heater can not be used under following circumstances:

- Constant heating for long time:
 - Living room, garage
 - Residential purpose boat
- Heat and dry:
 - Life(people, animal), blowing hot air directly
 - Articles and objects
 - Blow hot air to container

Heater Safety instruction of installation and operation

● Installation

Prevent the substances around heater from being damaged and influenced by high temperature.

● Exhaust emission system

When put the exhaust vent, prevent the exhaust entering the heating space through ventilator, hot air inlet and window. Keep the exhaust pipe clear. The exhaust pipe outlet shall be kept away from anything flammable, and avoid heating and igniting the flammable goods and loading cargo on the ground.

● The air inlet of combustion-supporting air

The combustion-supporting air which is used for heater burning shall not be inhaled from passenger compartment. The air inlet shall not be blocked, and keep the inlet open and clear. If the air inlet equipped with filter, keep the filter clean regularly.

● The heating air inlet

The heater air shall be composed by fresh air or circulating air, which is inhaled from clean area. The air inlet pipe shall be protected by safety fence or other suitable tools, and keep the pipe clear and open.

● The heating air outlet

In order to prevent the people and goods from being damaged, the hot air pipe shall be installed in the place where it could not be access to easily.

Safety instruction

- Following measures shall not be adopted
 - Change the important component of heater
 - Make use of the spare parts from other manufacturers without permission
 - Disobey the instruction and guide during installation or operation
- Only allow using original attachment and spare parts during installation and maintenance
- The heaters shall not be used in the places where may form flammable vapor or dust, for example:
 - Fuel depot
 - Carbon storehouse
 - Timber storehouse
 - Granary and similar sites
 - Diesel/petrol station
- The heaters shall be turned off when fill fuel
- If the fuel leak or discharge from the fuel system of heaters, please contact with the service provider to repair
- In the process of work, it is forbidden to cut off the electric power directly to stop the heater working

Product

Survey

KW2.0 Air heater (hereinafter referred to as the heater) is independent to the original engine system, it makes use of 12V or 24V direct current to drive. There are two kinds of control mode of the heater: Automatic control mode and Manual control mode. The heater adopts light diesel and gasoline which corresponds to the environmental temperature as fuel, and it can be started and operated normally at the temperature of above -40°C . The inhaled fresh air is heated to hot air through heat exchanger by the energy which comes from fuel burning, then blown to where it is needed. This type of heater owns the advantage of compact structure, light weight, high thermal efficiency, economize on electricity and fuel, easy installation.

Technical specification

Power (W)	2000	5000
Heating medium	Air	
Fuel	Diesel	
Fuel consumption (l/h)	0.12-0.24	0.18-0.48
Rated voltage (V)	12V / 24V	
Working temperature ($^{\circ}\text{C}$)	-50°C — 45°C	
Weight (KG)	3.6	5.2
Dimension (mm)	320x125x157	380x145x177

Structural principle

After the heater starts, the glow plug comes into operation, the magnetic pump begins to supply fuel, combustion-supporting fan inhales combustion-supporting air from outside of car. The fuel generates the heat by burning in combustion chamber, which is taken by aluminum heat exchanger. The inner air pushed by the heat

exchange fan brings heat to where it is needed through the surface of heat exchanger. And the combustion emission is discharged through exhaust pipe.

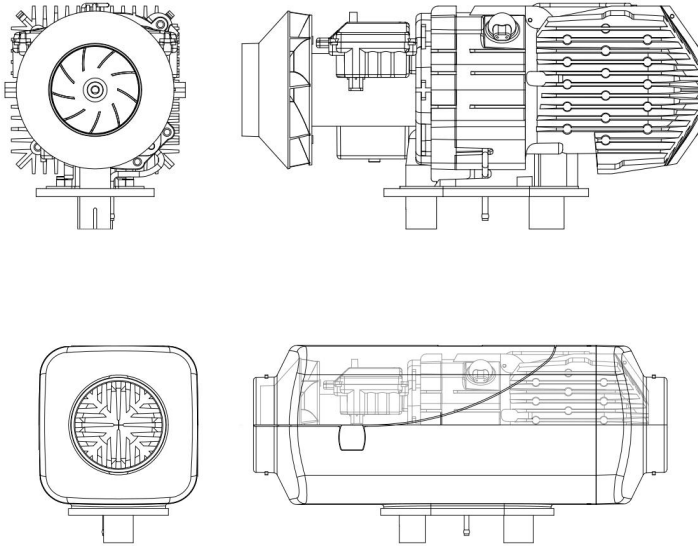

The structure of hood-shape case

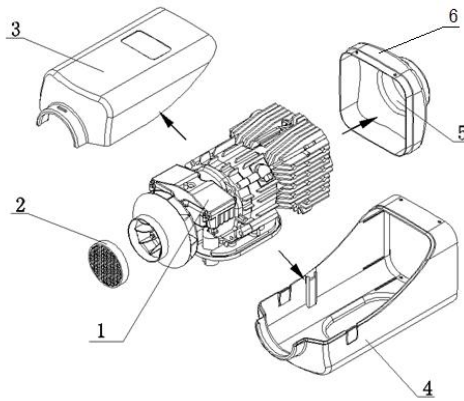

1-Main engine; 2-Suction hood; 3-Upper hood; 4-Bottom-hood; 5-Air outlet ; 6-Rear hood ; {Hood: Case/ Shell}

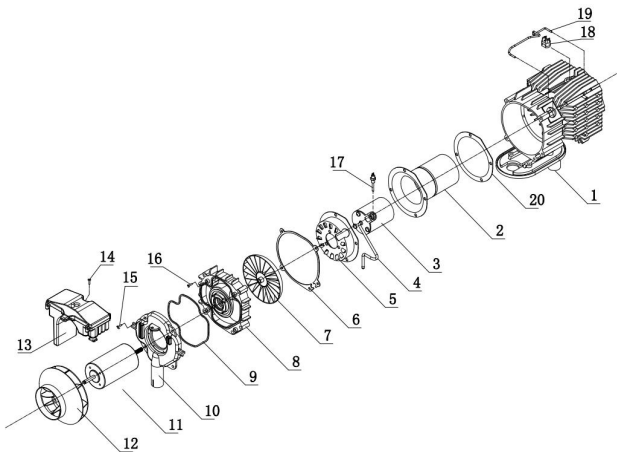

1.Exhaust tube 2.Combustion pipe 3.Combustor 4.Fuel tube 5.Air inlet distributor 6.Gasket 7.Combustion supporting fan blades
 8.Bracket of fan motor 9.Gasket 10.Combustion supporting air inlet 11.Fan motor 12. Blade wheel of heating fan 13.Main control panel
 14.Fixing screw 15.Fixing screw 16.Fixing screw 17.ignitor 18.heat sensor
 19. Sensor Fixed bracket

Installation

Only special-purpose parts can be used for installation of the heater. Following picture is the diagram for installation. The positions and ways of fixing of various parts may vary from one automobile model to another, but the general principles must be followed in conformity with the requirements of this chapter. Otherwise the heater may not work normally or safety problems may occur.

Main heater installation

The main heater could be installed both inside and outside of the vehicle. If the heater is installed outside the vehicle, measures must be taken to avoid splashing water onto the heater. Enough space must be provided for installation for the convenience of heating air flow and installation, maintenance of the main heater.

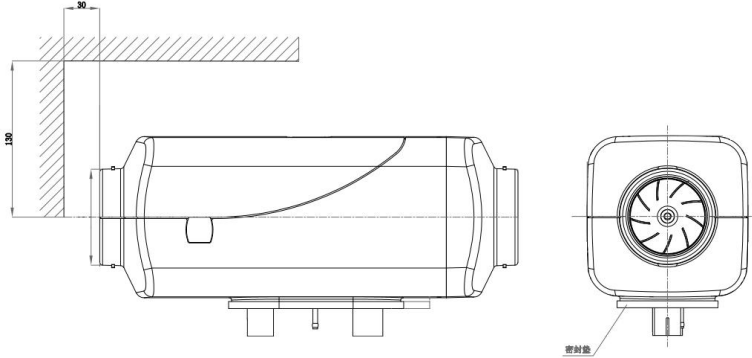

Good sealing is necessary between the main heater and the installation surface on the vehicle. The special gasket supplied by the manufacturer must be inserted in. And the installation surface must be even. Its parts at the installation bases of the main heater should have unevenness less than 1mm. After drilling installation holes, evenness must be improved according to this requirement. At installation, please rotate the four M6 nuts tight, which are provided by the manufacturer.

For re-installation of the main heater, a new gasket must be used to replace the old one.

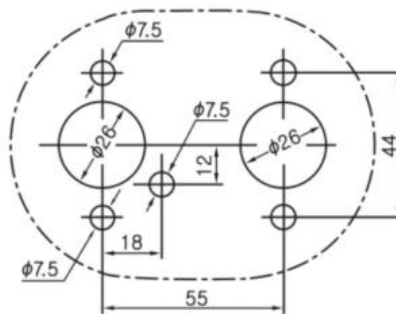

Attention must be paid to that the inclination angle shall not exceed the limit, or normal operation will be affected. Direction for installation of the main heater is shown in the following picture.

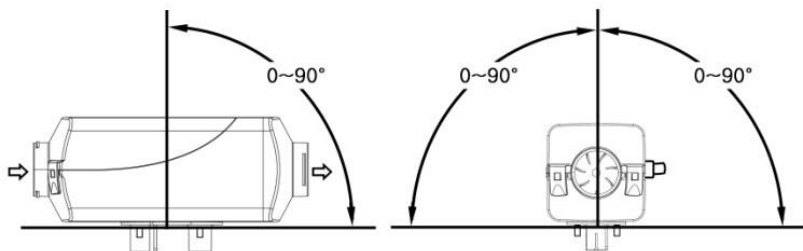

After installation of the main heater, please check and make sure that there is no contact or friction between the blade wheel of fan and other nearby parts to avoid unsmooth operation.

Installation of Air Heating System

The air heating system of the heater should not be connected with the air channel of the vehicle. Either independent outer circulation or inner circulation mode can be adopted.

When an external heating air tube is attached to the heater, the tube diameter should not be smaller than

85mm. Its material should be capable to resist temperature of 130°C.

The maximum pressure drop between the air inlet side and outlet side of the air heating system should not be higher than 0.15kPa.

The hot air from the heating system should not erupt onto such parts which are unable to resist heat. In passenger vehicles, the hot air vent should not be blocked by passengers. A self-provided protective net can be installed if necessary.

For heater working in external circulation mode, the position of air inlet port should be proper to guaranteed that under normal operation no splash of water can be sucked into the heater the no exhaust from the engine can be sucked in.

For heater working in internal circulation, measures should be taken to avoid re-entering of the supplied hot air into the air inlet port. If no air inlet tube is attached in this mode, an air inlet hood with grids must be installed at the air inlet port of the main heater. The inlet air should be drawn from the cold area of the compartment, such as under the seats or berths.

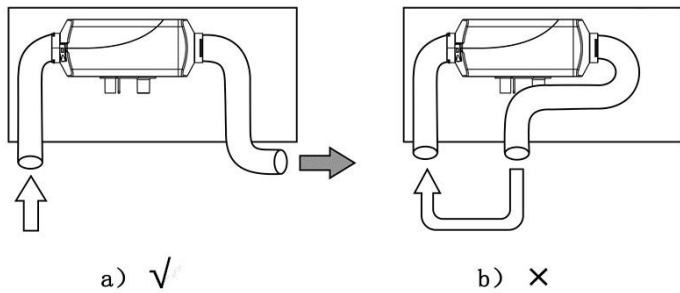

Installation of Fuel Supply System

Fuel for the heater can be supplied from the fuel tank of the vehicle or an additional independent fuel tank. It is not allowed to install the fuel tank in the cab or passenger compartment or any region that is possibly to cause fire if an independent fuel tank is used.

The elevation difference between the heater and fuel pump, and between the fuel pump and the fuel tank produces pressure from fuel to the fuel pump. The inner diameter and length of the fuel tube is related to the resistance of the fuel route. Please consider such factors for installation.

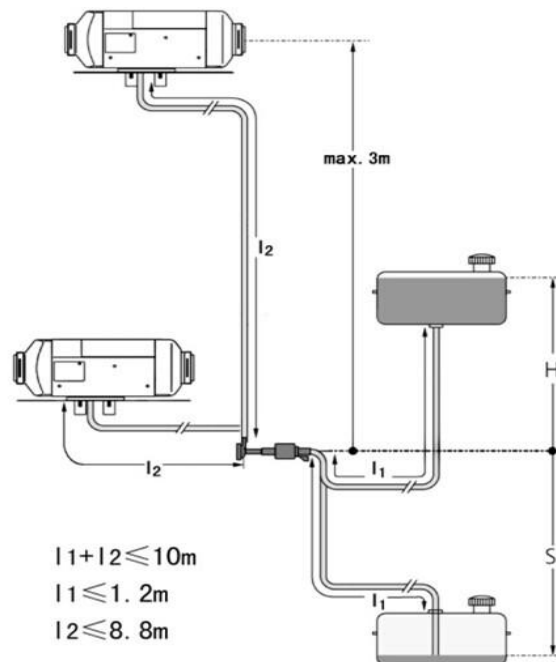

Fuel pump installation

The fuel pump should be installed in places that can avoid heat radiant from the vehicle parts that can emit heat

and in places with cool air. Its ambient temperature should not exceed 20 °C . Directions of installation of the fuel pump are shown in the following picture. When installing the fuel pump, please use the fuel pump holder supplied with the heater to hold the pump tight. The pump is fixed with the shock-reducing tightening piece.

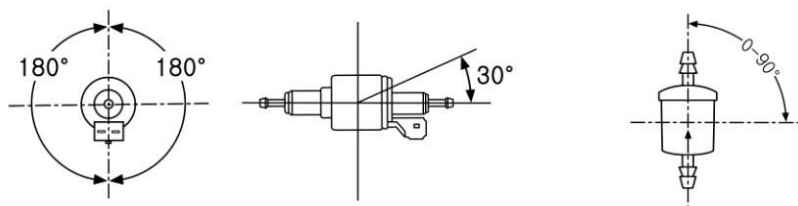

Fuel Filter installation

The fuel filter should be installed before the fuel inlet port. Please make sure that the fuel flow is correctly followed. Its position shall be in conformity with the above picture.

Installation of Fuel Tube

Only the flexible nylon tube, which has good light-resistance and thermal stability ,supplied with the heater can be used as the fuel tube. The inner diameter of the tube is Ø2mm.

The position of fuel tube should be against flying stones and be away from any heat emitting parts of the vehicle. Protective device can b installed if necessary.

The fuel tube from the fuel pump to the main heater should be in any directions other than downward direction. The fuel tube shall be tied in some proper location to make it fixed. The distance between two ties shall be less than 50cm.

The fuel tube fittings supplied with the heater should be used for connections between fuel tube and fuel pump, fuel tube and heater, fuel tube and sucking tube of fuel tank and fuel tube and reducing T. The fuel tube should tie with fuel tube clamps. Bubbles should be eliminated from the connecting places.

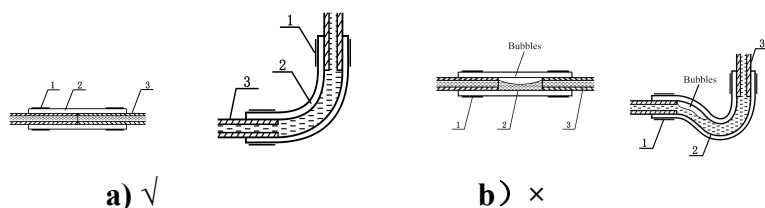

1-Fuel tube clamp; 2-Fuel tube fitting; 3-Fuel tube

Installation of Fuel Taking Device

The openings on the fuel tank (or tank cover) for installation should be appropriate in size, with trimmed brim and with good evenness around the opening. Good sealing is necessary for the base of the fuel taking tube. The bottom end of the fuel taking tube should be 30mm-40mm from the bottom of fuel tank to suck enough fuel and at the same time to avoid sucking in impurities sediment on the bottom of fuel tank.

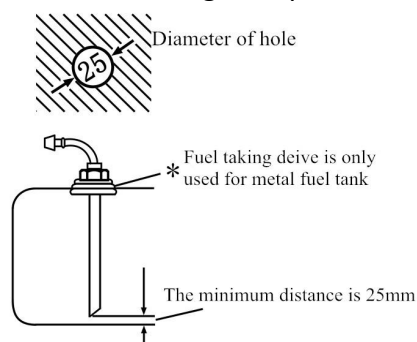

If fuel is taken from the fuel pipe to the engine, the fuel pipe from the fuel tank to the fuel filter should be disconnected and re-connected with the thicker pipes of the reducing T. And the thinner pipe of the reducing T should connect the fuel pump of the heater via fuel tube fitting and tube. The angle of installation must in conformity with following picture, or normal work of the heater will be affected.

After installation, the vehicle engine shall be started and then turned off after one minute's work to eliminate air trapped in the fuel sucking pipe.

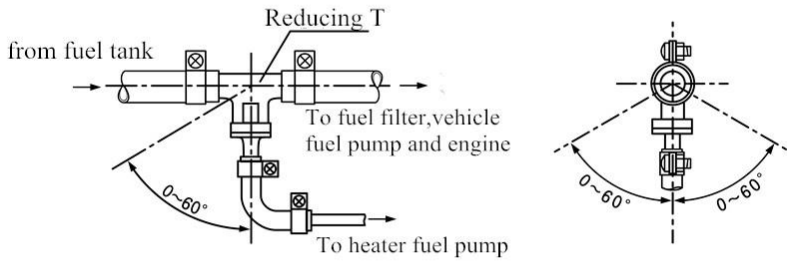

Installation of Electrical System

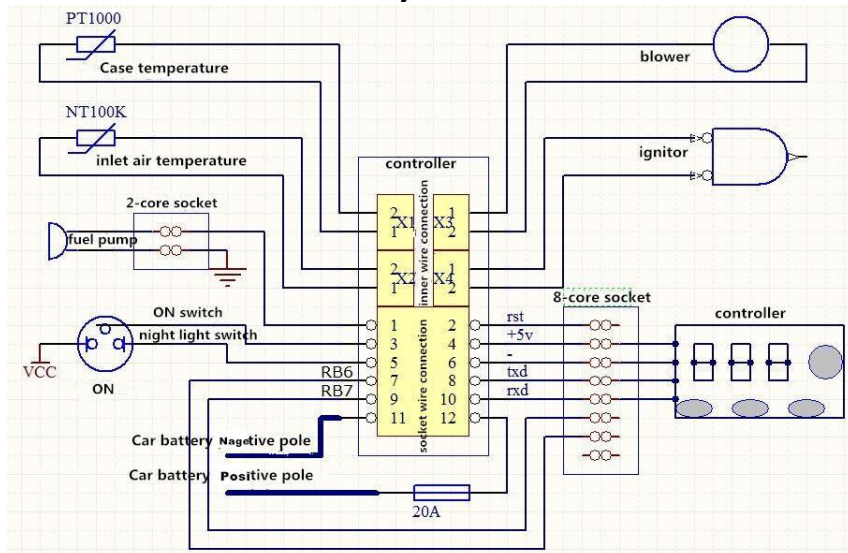

Installation of Combustion Supporting Air Sucking Tube and Exhaust Discharge Tube

The combustion supporting air must be sucked in from external fresh air outside the vehicle. The exhaust from combustion must be discharged into the air through exhaust tube. Measures must be taken to avoid the exhaust from re-entering the vehicle.

The tubes go through the outer wall or holes on the bottom of vehicle. Measures must be taken to prevent entering of splash water. The tubes must be protected and can resist shock permanently.

Only the air inlet tube and exhaust tube provided with the heater can be used. The air inlet tube is a corrugated pipe made of an aluminum tube that its surface is covered by plastic and paper: The exhaust tube is corrugated stainless steel tube. Please identify them and do not make mistake at installation. To connect them with heater, please use the supplied clamps to fix them tightly on the combustion supporting air inlet and exhaust tube vent respectively. The protective hood on the vents of the air inlet tube and exhaust tube must be kept in good condition. Do not damage them or remove them.

Both the air inlet tube and the exhaust tube should come outwards and downwards from the heater, otherwise a $\varnothing 4\text{mm}$ hole shall be prepared at the bottom of the tube for discharge of condensation water. If the tube needs a curve, the radius cannot be smaller than 50mm. Also, the sum of all curve angles for each tube shall not exceed 270°C .

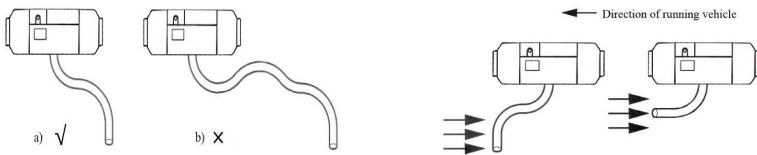

The opening of the tubes should not be opposite to the direction of the running vehicle.

The tube openings should not be blocked by slurry, rain and snow or other dirt.

The exhaust tube should be installed in far distance from the plastic parts or other objects with poor thermal resistance of the vehicle body. The exhaust tube should be properly fixed. The exhaust vent should be downwards, perpendicular to road surface with angle of $90^\circ \pm 10^\circ$. To ensure such an angle, the fixing clip for the exhaust tube should be within 150mm from the tube end.

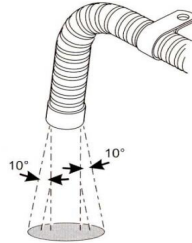

Warning: Violation against the above requirements may cause fire.

If the section of the exhaust tube inside the vehicle may be touched by passenger, a protective cover has to be installed to prevent human contact and scald.

Installing picture:

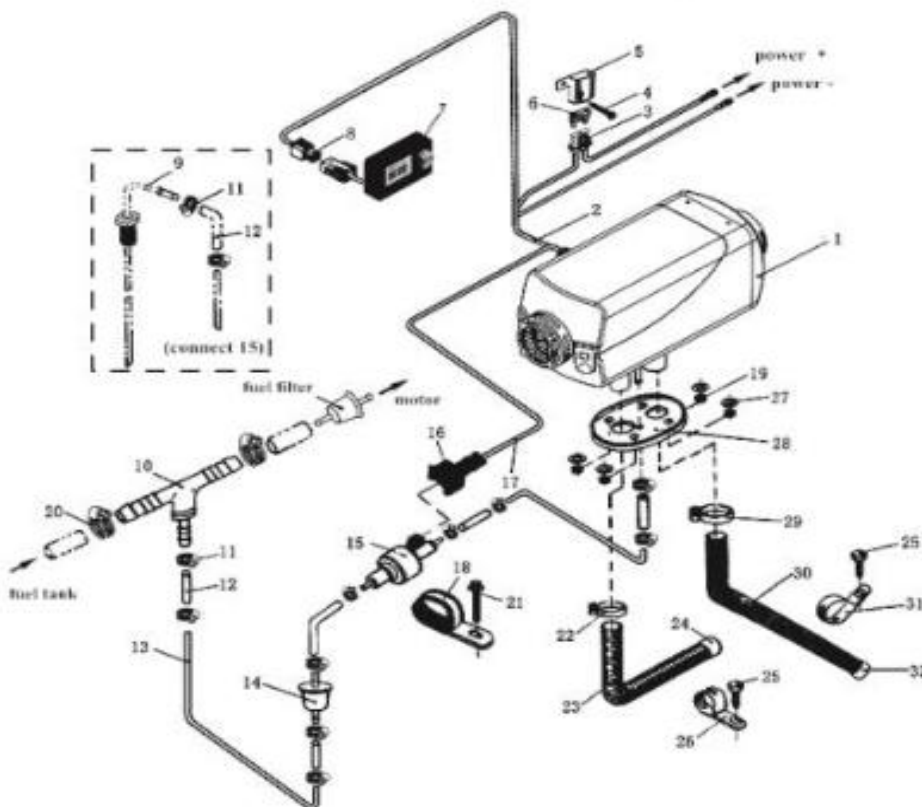

- 1–Main heater;
- 2–Main wire hardness assembly;
- 3–Fuse holder;
- 4–Self-tapping screw;
- 5–Fuse box cover;
- 6–Plug sheet fuse;
- 7–Controller;
- 8–Connector X9 for control switch;
- 9–Fuel sucking pipe;
- 10–Reducing T;
- 11–Fuel tube clamp;

- 12–Fitting of fuel tube;
- 13–Fuel tube;
- 14–Fuel filter;
- 15–Fuel pump;
- 16–Fuel pump connector;
- 17–Fuel pump leads;
- 18–Fuel pump holder;
- 19–M6 Screw;
- 20–Fuel tube clamp;
- 21–Self-drilling and self-tapping screw 5.5 × 30;
- 22–Air inlet tube clamp;
- 23–Air inlet tube;

- 24–Protective hood for air inlet tube;
- 25–Self-drilling and self-tapping screw 5.5 × 20;
- 26–Fixing clip for air inlet tube;
- 27–Washer;
- 28–Gasket;
- 29–Exhaust tube clamp;
- 30–Exhaust tube;
- 31–Fixing clip for exhaust tube;
- 32–Protective hood for exhaust tube;
- 33–Self-tapping screw

Maintenance

During the running of heater, it tests and checks the operating state and fault in the whole course, and the controller shows fault codes on the LCD / LED constantly.

The fault code of LCD screen:

E01~  Power supply voltage is too low. (Min 10.5V)

E02~  Power supply voltage is too high. (Max 14V)

E03~  Ignition/ Spark plug is open or short circuit.



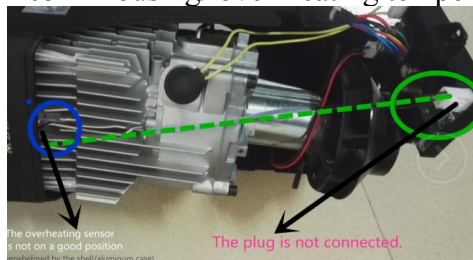

E04 ~  Fuel pump is open or short circuit.

E05 ~ Housing/ over-heating temperature sensor is open or shorted. (It is on the aluminum shell.)

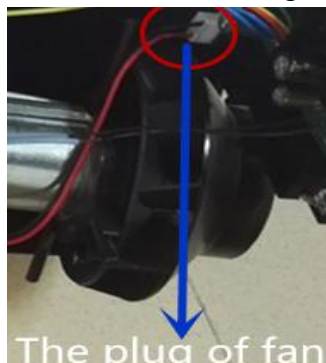
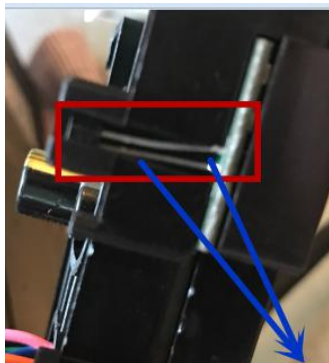

E06 ~ ①. The fan is stuck. ②. The Hall sensor of Fan is open or shorted. ③ Plug is open



E07 ~  LCD display screen is disconnected to heater body.

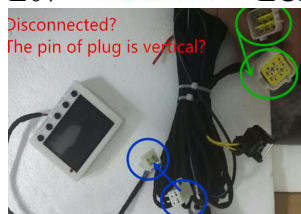

E08 ~ flame off failure
If there is air /blockage in oil road.

E09 ~ **Inlet sensor** is open or shorted.

E10 ~ Ignition failure.
The oil road is blocked / Air airbubbles.

(The fuel pipe from pump to heater should be 1.2- 2 meter)

After -sales Service ~ Micahel: 489673700@qq.com

Operation and Control

After the installation, the heater shall be turned on repeatedly for a few times to make the fuel tube full-filled, so as to avoid starting failure due to lacking fuel.

Controller

12V-24V LCD display manual



1 . Function

◀ -> Setting state, increase the data; If not, increase Hz/°C.



-> Press 1 " **off** Press 3 " **off**



-> Setting state, decrease the data; If not, decrease Hz/°C

The basic operation uses the above, and the settings uses the following operation:



Setting->Enter Setting state, adjust data, change working status.



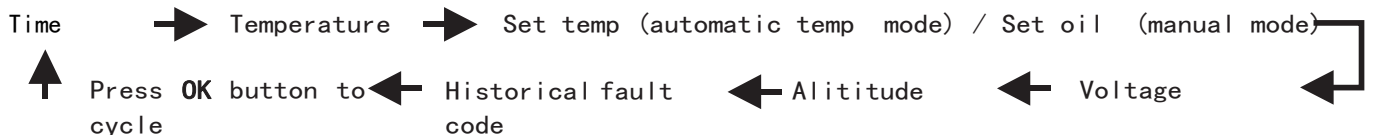

-> Setting state, confirm the current data, and enter the next data to set; if not,

2 . Check the Setting state (Pres **OK**: Each time press to switch next state.)





3 Manual fueling description:

In the off state, press and hold  **and OK** to enter the manual fueling. -Off.

After releasing, press  to start the operation. You can hear the working sound of the pump and the pump icon lights up. Press  to exit the fuel fill and the pump icon disappears.

The process of emptying air from the pipeline needs to be observed. When the oil reaches the position of the oil inlet of the machine, it can stop. Excessive fuel enters the machine and there will be black smoke.

4 . The switching description of Temperature control mode:

Press and hold **the up**  **and OK**  at the same time to switch the temperature control mode, manual temperature control , automatic temperature control

The difference between the two temperature control methods is that the automatic mode pump oil can reach the maximum value of the parameter setting, the machine heat is higher, the manual mode pump oil quantity is limited to the current set value, and the parameter setting maximum oil quantity value will not be reached

5. The match of Remote control and LCD:

On the “off” state. First, press the “power” and “confirm” button simultaneously on Remote controller until LCD screen displaying “ wait for matching ” . Second, press off” and “on” button on the LCD screen for 3~5 seconds, then the screen will enter the “ matching ” interface. After match, it will exit

automatically and display the normal working parameters.
Any match failure, no displaying about the normal working parameters. Overtime fail to match, exit the “matching” interface automatically also.

6. Parameter setting description (press the setting button to enter the setting state)

1. time setting --- Press the on or off button to adjust the parameters --- Set the hour (24 hour system), minute and other parameters, press the confirm button , then enter to the next interface.

2. Timing power-on Setting ---- Default off, display off, press on button then show the off , press confirm button-- Set hours and minutes in turn, timing by countdown, Max be 99 minutes and 59 seconds.

3. Timing power-off Setting --- Default off, display off, press on button then show the off , press confirm button-- Set hours and minutes in turn, timing by countdown, Max be 99 minutes and 59 seconds.

4. Input manage passport --Press the “ on” or “off” button until it reach the correct value, then press the confirm button enter next interface, Any input error, it will come back to the first digit. then no need to modify subsequent data, press the set button until exit, or wait for 10 seconds for exiting automatically.

5. Pump oil flow setting---Press the “ on” or “off ” button to adjust minimum pumping oil flow. after reach the value, press confirm button to set the max oil flow----Press the “ on” or “off ” button to adjust maximum pumping oil flow. after reach the value , press confirm button to enter next

interface.

6. Fan speed setting---Press the “ on” or “off ” button to adjust min speed. after reach the value, press confirm button to set the max speed. Press the“ on” or “off ”button to adjust max speed .after reach the value , press confirm button to enter next interface.

7. Ignition plug power selection

-----motherboard operating voltage can be only selected under “off” state! Press the “on” or “off” button to switch--Set the working voltage, adjust the 12V system to display V-12, adjust the 24V system to display V-24, finish select. Please check the match satus of oil pump, motor and ignition plug before turn-on.

-----Display 5N-1, Press the“ on” or “off ”button to set the speed signal, same polarity for 2 magnets on impeller, select 5N-2, different polarity for 2 magnets on impeller or only 1 magnet (Defaults), select 5n-1. Any error for this parameters, 1 times difference for the speed will lead to!

8. Ignition plug power selection, dispaly RF-5 , press the “ on” or “off ”button, modify the value (1=35W, 2=40W, 3=45W, 4=80W, 5=85W, 6=90W) Default value kindly recommend use the default value or modify the value after verification.

9. manage password modification---Initial display off status, no need to change, press confirm button to skip the password modification, and save above modified parameters. Press the on button when modifying. Display oN status, press to confirm and enter the password modification status, press the on or off button to adjust. After the 4-digit password is entered correctly, press confirm button to enter next

interface. After saving the new password and adjusting the setting parameters, it will exit automatically .